

Full Range of Kerbs

Tracey Concrete manufactures a full range of precast Kerbs made to BS EN 1340.

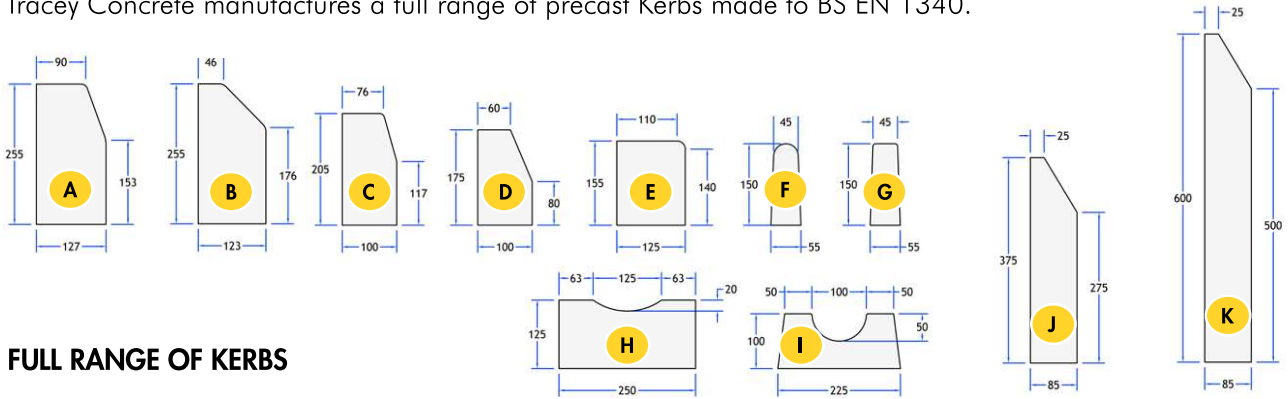

FULL RANGE OF KERBS

	Type of Kerb	Depth	Width	v	Approx Weight	Pressed / Wetcast
-	-	mm	mm	mm	KG	-
A	10 x 5 Half Battered	255	127	910	61	Pressed
B	10 x 5 Kerb Full Battered	255	123	910	57	Pressed
C	8 x 4	205	100	910	39	Pressed
D	7 x 4	175	100	910	31	Wetcast
E	6 x 5 Bullnose	155	125	910	39	Pressed
F	6 x 2 Round Top	150	55	910	14	Wetcast
G	6 x 2 Flat Top	150	55	910	15	Wetcast
H	10 x 5 Channel	125	250	910	59	Pressed
I	9 x 4 Channel	100	225	910	35	Wetcast
J	Dwarf Wall	375	85	910	58	Wetcast
K	Dwarf Wall Deep	600	85	910	96	Wetcast

